

## Reducing Coupling

Fig. A - Tapered sleeve design

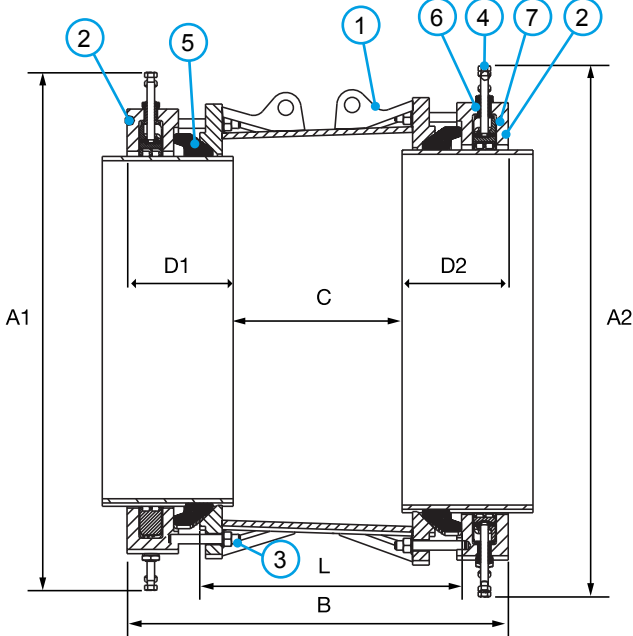
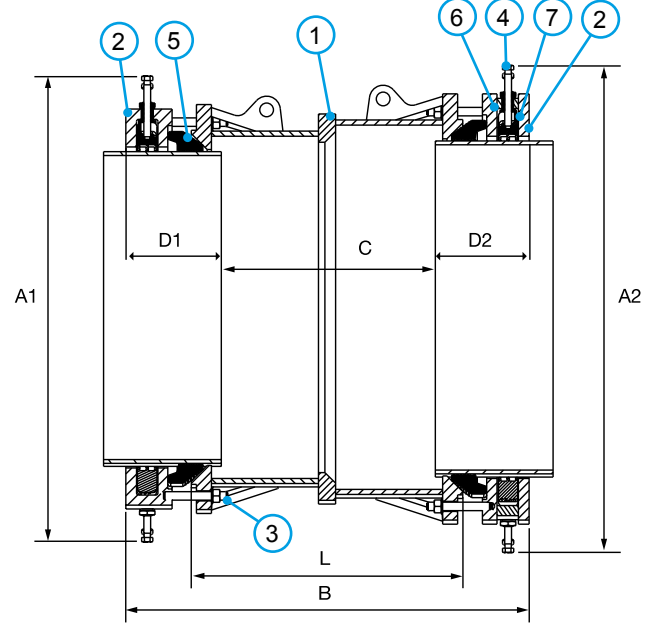

Fig. B - Make up ring design



**HAZARD WARNING:** Lifting lugs, where provided, are designed/ tested for lifting only the components to which they are attached. Failure to follow these instructions could result in property damage, serious personal injury or death. The maximum safe working load of the lifting eye is equal to the product weight.

**Key**

- 1 = Centre Sleeve
- 2 = End Ring
- 3 = Studs
- 4 = Bolt, Nut & Washer
- 5 = Gasket
- 6 = Square Bush Nut
- 7 = Gripper

### Reducing Couplings

Nom Size		Size Range				Insertion Depth				Setting Gap		Dimensions				Fasteners				Weight (kg)	
Small End	Large End	Small End		Large End		Small End (D1)		Large End (D2)		(C)		Overall				Small End		Large End			
		Min	Max	Min	Max	Min	Max	Min	Max	Min	Max	A1	A2	B	L	Radial Bolt No-size	Axial Bolt No-size	Radial Bolt No-size	Axial Bolt No-size		
<b>Fig. A: Tapered Sleeve Design</b>																					
700	700	700	735	727	762	220	245	220	245	310	360	1085	1115	800	494	24 X M16	16 X M20	32 X M16	16 X M20	580.03	
700	700	727	762	750	785	220	245	220	245	310	360	1115	1135	800	494	32 X M16	16 X M20	24 X M16	16 X M20	611.58	
700	800	727	762	789	824	220	245	220	245	315	365	1115	1175	805	496	32 X M16	16 X M20	30 X M16	18 X M20	635.71	
800	800	825	860	853	888	220	245	220	245	320	370	1210	1240	810	496	40 X M16	18 X M20	30 X M16	18 X M20	705.17	
<b>Fig. B: Make Up Ring Design</b>																					
700	700	700	735	750	785	220	245	220	245	450	500	1085	1135	940	634	24 X M16	16 X M20	24 X M16	16 X M20	666.69	
700	800	700	735	789	824	220	245	220	245	455	505	1085	1175	945	496	24 X M16	16 X M20	30 X M16	18 X M20	635.71	
800	800	789	824	825	860	220	245	220	245	460	510	1175	1210	950	638	30 X M16	18 X M20	40 X M16	18 X M20	1054.65	
800	800	789	824	853	888	220	245	220	245	455	505	1175	1240	945	496	30 X M16	18 X M20	30 X M16	18 X M20	762.91	

### Connections based on standard pipe OD's\*

Nom Size	Range		Ductile Iron	PE / MOPVC	Steel / FBE Coated Steel	Cast Iron	Asbestos Cement
	Min	Max					
DN700	700	735		710mm	DN700	26" (AB & CD)	26" (AB & CD)
DN700	727	762	DN700			27" (AB & CD)	27" (AB & CD)
DN700	750	785			DN750	28" (AB & CD)	28" (AB & CD)
DN800	789	824		800mm	DN800	30" (AB)	30" (AB)
DN800	825	860	DN800				
DN800	853	888				32" (AB & CD)	32" (AB & CD)

\*The above table is for guidance only, please ensure the OD and material of the pipe is compatible before installation

### Working Pressure & Temperature Ratings

Nominal Size	Gripping Product		Flex Product		Operating Temperature
	Gas	Water	Gas	Water	
DN700	N/A	16 bar	N/A	16 bar	-20 to +60
DN800	N/A	16 bar	N/A	16 bar	

### Pipe Materials



### Reducing Couplings

### Technical Information

#### Working pressure rating:

Water:  
DN700 to DN800 = 16 bar  
Gas:  
Not approved

#### Site test pressure:

1.5 times working pressure

#### Angularity

Couplings 8°, +/- 4° angularity on each side

#### Gripping product suitable for

Ductile iron / PE (PE100, SDR 11, 17, 21, 26)  
Steel / Cast iron / MOPVC (SDR 33)

#### Flex product suitable for

Ductile Iron / PE (PE100, SDR 11, 17, 21, 26)  
Steel / Cast Iron / MOPVC / Asbestos Cement

Bolt Torque	Recommended Bolt Torque (Nm) on every bolt				
	Bolt Size	Ductile Iron	PE-100	Steel & Cast Iron	MOPVC
<b>Axial Fastener</b> (For Gasket Engagement)	M20	190-210	190-210	190-210	190-210
<b>Radial Fastener</b> (For Grippers)	M16	175-185	140-150	110-120	95-105

For the full installation details and to ensure correct fitting, please refer to the UltraGrip DN700 DN800 installation instructions.

#### Temperature rating of product

Operating temperature -20°C to +60°C

#### Support liners – PE and MOPVC pipes

A close fit Viking Johnson support liner is required when used on:

- All PE pipes
- MOPVC pipes

#### Use of restrained couplings on exposed pipework

UltraGrip can be used in above ground applications, so long as the pipework is supported, it is not exposed to direct sunlight and falls within the 40°C operating temperature range (between -20°C and +60°C).

#### Approvals

The following water contact materials used in UltraGrip are approved for use with potable water:-

- Rilsan Nylon 11:
- WRAS, DVGW, W270, ACS & KIWA
- Gasket (EPDM):
- WRAS, W270

#### Finished Product:

BS8561; WRc certification verifying that the product complies with BS8561 (Specification for mechanical fittings for use in the repair, connection and renovation of pressurized water supply pipelines — Requirements and test methods).

Polyethylene Pipe Pull Out Performance; WRc certification confirming on PE a Type 2 end load performance (defined in IGN 4-01-02:2017 [N3]) when tested in accordance with the method given in BS EN ISO 3501.

## Materials & Relevant Standards

#### 1) End Rings 2) Centre Sleeve

Mild steel to BS EN10025 Grade S355

#### 3) Studs

Stainless steel – BS EN ISO 3506-1 Grade A4-80

#### 4) Bolts

Stainless steel to BS EN ISO 3506-1 Grade A4-80

#### 4) Nuts

Stainless steel – BS1449:PT2 ISO 3506-1 Grade A4-80

#### 4) Washers

Stainless steel – BS1449:PT2 ISO 3506-1 Grade A4-50

#### 5) Gasket

EPDM to BS EN 681-1

#### 6) Square Bush Nut

Cast stainless steel to ASTM A487/A487M-21, Grade CA6NM Class A

#### 7) Gripper

Stainless steel (Cast) PH 17-4 H925 to BS EN 10088-1

#### Retention Insert

Nylon 6

#### Coatings

End Rings / Centre Sleeve / Flange:

- Rilsan Nylon 11 (Black)

Bolts:

- Dry Film Lubricant GZ – Silver

Nuts:

- Dry Film Lubricant GZ – Silver

Gripper - None