

AquaFast Large Diameter Flange Adaptors 355mm to 450mm

Datasheet 1/2

Flange Adaptor

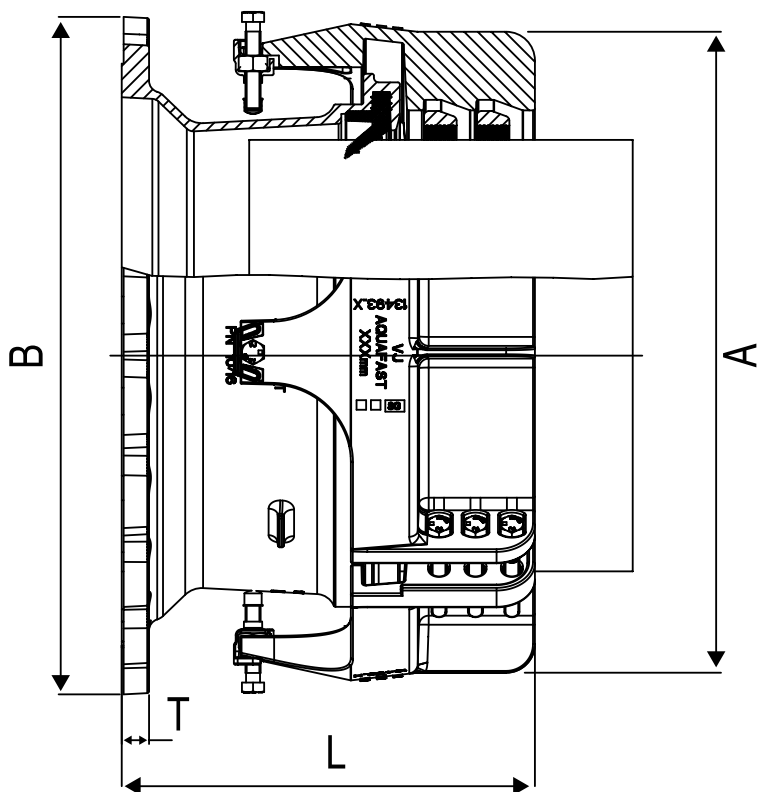

AquaFast Flange Adaptors

| Nominal Size | Flange Drilling | Working Pressure (water) bar | Bolts size No dia x length | Insertion Depth (mm) | | | Setting gap (based on nominal insertion depth) | Outer Dimensions (mm) | | | | Weight (kg) | |
|--------------|-----------------|------------------------------|----------------------------|----------------------|-----|-----|--|-------------------------------|-------------|------------|---------------------------|-------------|----------------------|
| | | | | Min | Nom | Max | | Clamp Band Outer Diameter (A) | | Length (L) | Flange Outer Diameter (B) | | Flange Thickness (T) |
| | | | | | | | | Installed | Uninstalled | | | | |
| 355 | 300 PN10,16 | 16 | 12-M16 x 120 | 284 | 304 | 324 | 197 | 540 | 571 | 501 | 455 | 22.5 | 122.2 |
| 355 | 350 PN10,16 | 16 | 12-M16 x 120 | 284 | 304 | 324 | 117 | 540 | 571 | 421 | 520 | 23.5 | 120.0 |
| 400 | 350 PN10,16 | 16 | 12-M16 x 120 | 289 | 309 | 329 | 183 | 585 | 618 | 492 | 520 | 23.5 | 134.4 |
| 400 | 400 PN10,16 | 16 | 12-M16 x 120 | 290 | 310 | 330 | 117 | 585 | 618 | 427 | 580 | 25 | 132.0 |
| 450 | 400 PN10,16 | 16 | 12-M16 x 120 | 298 | 318 | 338 | 109 | 635 | 670 | 427 | 580 | 25 | 142.9 |
| 450 | 450 PN10,16 | 16 | 12-M16 x 120 | 298 | 318 | 338 | 117 | 635 | 670 | 435 | 640 | 27 | 147.2 |
| 450 | 500 PN10,16 | 16 | 12-M16 x 120 | 298 | 318 | 338 | 117 | 635 | 670 | 435 | 715 | 28.5 | 155.4 |

Every effort has been made to ensure that the information contained in this publication is accurate at the time of publishing. Crane Ltd assumes no responsibility or liability for typographical errors or omissions or for any misinterpretation of the information within the publication and reserves the right to change without notice.

DR10998_01_10_2024_ISSUE 8

AquaFast Large Diameter Flange Adaptors 355mm to 450mm

Datasheet

2/2

Technical Information

Working Pressure Rating

Water 16 bar

Gas not approved

Vacuum Pressure

Capable of accommodating a vacuum pressure of -0.8 bar

Site Test Pressure

1.5 times working pressure for short duration (2 hours)

Pipe Material / Support Liner

When used on the following pipe materials AquaFast does not need a support liner:-

- ▶ MDPE (PE80) in SDR ratings 11 & 17/17.6
- ▶ HDPE (PE100) in SDR ratings 11, 17/17.6 & 21

Angularity (in accordance with BS EN 12842)

Flange Adaptors 1.0°

Bolt Torque

Torque Wrench; Tighten using spanner of sufficient length to ensure enough leverage is applied to cause resistors to collapse evenly until fitting the metal to metal positive stop is achieved.

Specialist Equipment

None required, only a rag to clean pipe and a spanner or wrench. The length of the Spanner or Torque Wrench used to tighten the bolts must be sufficiently long to ensure enough leverage is applied to cause resistors to collapse evenly until fitting the metal to metal positive stop is achieved.

Temperature Rating of Product

EPDM -20°C to +60°C

AquaFast is not suitable for use on heating systems with fluctuating temperatures.

End Load Due to Internal Pressure

AquaFast Fully restrained fitting, and has been designed to meet the performance requirements of BS EN 12842, ISO 17885 and IGN 4-01-02 (formally WIS 4-24-01).

Approvals

The following water contact materials used in AquaFast are approved for use with potable water:-

Rilsan Nylon 11:

- ▶ WRAS, DVGW, W270, ACS & KIWA

EPDM Gaskets:

- ▶ WRAS

In addition to the above, AquaFast as a finished product has KIWA certification verifying that the above products comply with the requirements of the Water Supply (Water Fittings) Regulations for England and Wales 1999, the Water Byelaws 2000, Scotland and the Water Regulations Northern Ireland.

Materials & Relevant Standards

Flange Adaptor Body, Centre Sleeve, Clamp Bands & Gripper Ring

Ductile iron to BS EN 1563 Symbol EN-GJS-450-10

Gasket

EPDM Grade 'E' to BS EN 681-1:1996 Type WA WRAS listed

Coatings

Body, Sleeve, Intermediate Ring & End Ring

- ▶ Rilsan Nylon 11 to WIS 4-52-01 Part 1

Nuts and Bolts:

- ▶ Delta Seal GZ - Silver

Gripper:

- ▶ Cathaphoretic coating

Bolts

Standard - Stainless Steel BS EN ISO3506-1 Grade A2-70

Nuts

Standard - Stainless Steel BS EN ISO3506-2 Grade A4-80

Washers

Stainless Steel to BS1449: Part 2:1983 Grade 304S15

Every effort has been made to ensure that the information contained in this publication is accurate at the time of publishing. Crane Ltd assumes no responsibility or liability for typographical errors or omissions or for any misinterpretation of the information within the publication and reserves the right to change without notice.

DR10998_01_10_2024_ISSUE 8