

FlexLock Couplings

Datasheet

1/2

Coupling

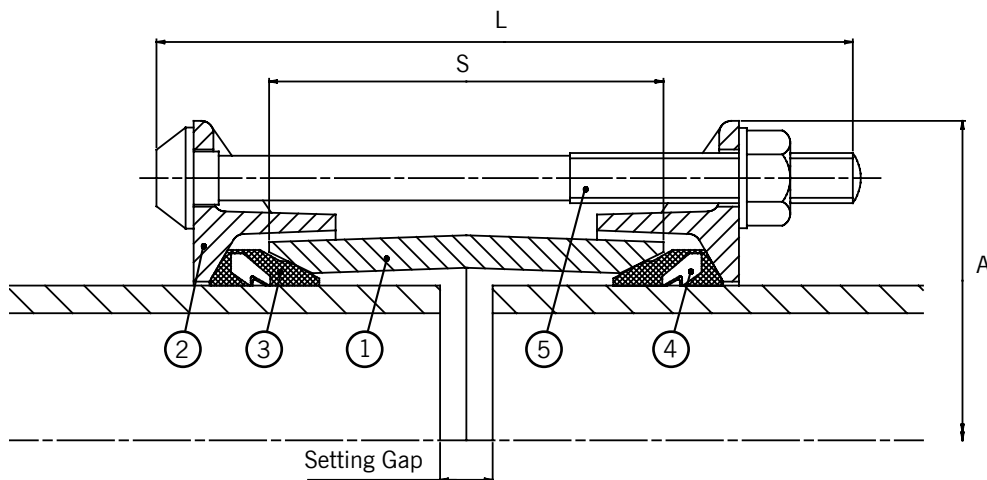

Key

- 1 = Sleeve
- 2 = End Ring
- 3 = Gasket
- 4 = Gasket Gripper Teeth
- 5 = Bolts, Nut & Washer

FlexLock Couplings

Pipe Nom	Pipe OD (mm)	Pipe Material	Bolt Size No.-Dia x Length	Overall Length (L)	End Ring OD (A)	Sleeve Length x Thickness (mm) (S)	Setting Gap		Working Pressure (bar)		Gasket Mould	Coupling Weight (kg)
							Min	Max	Water	Gas		
DN50/2"	60.3	Steel	2-M12 x 145	157	135	80 x 5.5	15	30	16	6	1375	2.7
DN65/2.5"	76.1/77	Steel	2-M12 x 160	170	152	100 x 6.0	20	40	16	6	1394	3.2
DN80/3"	88.9	Steel	4-M12 x 160	170	163	100 x 6.0	20	40	16	6	1382	4.2
DN80/3"	98.0	Ductile Iron	4-M12 x 195	203	181	115 x 6.4	20	40	16	6	1630	5.2
DN100/4"	114.3	Steel	4-M12 x 170	188	195	100 x 6.0	20	40	16	6	1367	6.1
DN100/4"	118	Ductile Iron	4-M12 x 195	203	200	115 x 6.4	20	40	16	6	1618	5.6
DN150/6"	165.1	Steel	6-M12 x 170	188	254	100 x 7.2	20	40	16	6	1369	9.2
DN150/6"	168.3	Steel	6-M12 x 170	188	256	100 x 7.2	20	40	16	6	1369	9.3
DN150/6"	170	Ductile Iron	6-M12 x 170	178	256	100 x 7.2	20	40	16	6	1369	9.2
DN200/8"	219.1	Steel	8-M12 x 170	188	310	100 x 7.2	20	40	16	6	1370	11.9
DN200/8"	222	Ductile Iron	6-M16 x 195	206	316	115 x 6.4	20	40	16	6	1631	12.0
DN250/10"	273.0	Steel	12-M16 x 275	286	376	178 x 8.5	20	40	10	6	1737	32.2
DN250/10"	274	Ductile Iron	12-M16 x 275	286	376	178 x 8.5	20	40	10	6	1737	32.2
DN300/12"	323.9	Steel	12-M16 x 275	286	436	178 x 6.0	20	40	10	6	7667/8	33.7
DN300/12"	326	Ductile Iron	12-M16 x 275	286	436	178 x 6.0	20	40	10	6	7667/8	33.7

Every effort has been made to ensure that the information contained in this publication is accurate at the time of publishing. Crane Ltd assumes no responsibility or liability for typographical errors or omissions or for any misinterpretation of the information within the publication and reserves the right to change without notice.

DR10998_01_10_2024_ISSUE 8

Technical Information

Working Pressure Rating

Water:

- DN50 to DN200 = 16 bar
- DN250 to DN300 = 10 bar

Gas:

- DN50 to DN300 = 6 bar

Vacuum Pressure

Capable of accommodating a vacuum pressure of -0.7 bar

Site Test Pressure

1.5 times working pressure for short duration (2 hours)

Angularity

Couplings 6°

Bolt Torque/Spanner

M12; Torque 55-65Nm on every bolt

M16; Torque 95-120Nm on every bolt

Temperature Rating of Product

EPDM -20°C to +40°C

Nitrile -20°C to +40°C

General Notes

- FlexLock is only suitable for use on Ductile Iron, Steel and Coated Steel Pipe
- For coated steel pipe the maximum permitted coating thickness is 500µ DFT. This is to ensure the stainless steel teeth properly grip onto the pipe surface to mobilize the end load capability of the products.
- Due to the surface characteristics of stainless steel pipe, FlexLock grippers are unable to achieve a guaranteed grip on the pipe surface.
- If the product has to be dismantled after installation then for reassembly a new gasket must be used, as there is a risk that the stainless steel teeth may become dislodged during this operation. These are available as spares from Viking Johnson by quoting gasket mould number from the table along with gasket compound.

Approvals

The following water contact materials used in FlexLock are approved for use with potable water:-

Rilsan Nylon 11:

- WRAS, DVGW, W270, ACS & KIWA

EPDM Gaskets:

- WRAS

In addition to the above, FlexLock range as a finished product has KIWA certification verifying that the above products comply with the requirements of the Water Supply (Water Fittings) Regulations for England and Wales 1999, the Water Byelaws 2000, Scotland and the Water Regulations Northern Ireland.

Materials & Relevant Standards

Centre Sleeve & End Ring Options:

- SG. Iron to BS 1563: Symbol EN-GJS-450-10
- Rolled Steel to: BS EN 10025: Grade S275

Coupling Body Options:

- Ductile Iron to BS EN 1563 EN-GJS-450-10
- Mild Steel to: BS EN 10025: Grade S275

Gasket

EPDM compound Grade E to BS EN 681-1

Nitrile compound Grade 'G' to BS EN 682-1

Gasket Gripper Teeth

Stainless Steel BS 3146: Part 2 Grade ANC2

Coatings

Body, Centre Sleeve, & End Rings:

- Rilsan Nylon 11 to WIS 4-52-01 Part 1

Bolts, Studs & Nuts:

- Sheraplex coated to WIS 4-52-03

Bolts

Cold Forged Steel Fasteners to: BS EN ISO898-1: Property Class 8.8

Nuts

Steel BS EN 20898-2: Property Class 8

Washers

BS 4320 Form B Stainless Steel BS 1449:PT2: Grade 304 S15