

Large Diameter Flange Adaptors OD355 - 945mm to BS EN 1092-1 PN25 Drilling

Datasheet

1/4

Flange Adaptor

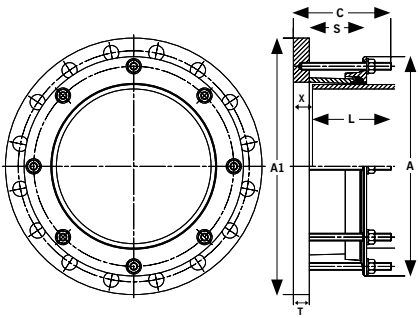

Flange Adaptor Type	Flange Adaptor Section	Sleeve Length S (mm)	Distance L (mm)	Setting Gap X (mm)		Bolt Details		
				Min.	Max.	Bolt Dia.	Length (mm)	Torque (Nm)
Standard Sleeve	L02	73	150	25	50	M12	140	55 - 65
Long Sleeve	L03	123	200	25	100	M12	180	55 - 65
Standard Sleeve	YF2	87	150	32	76	M16	160	95 - 120
Long Sleeve	YF3	123	200	32	115	M16	190	95 - 120
Standard Sleeve	A2E	87	150	32	76	M16	160	95 - 120
Long Sleeve	A2H	125	200	32	115	M16	190	95 - 120
Standard Sleeve	XSVG	254	200	57	117	M16	400	95 - 120

L = Distance back from end of pipe that must be rounded, meet tolerances, and free from any wrapping to ensure correct assembly.

Large Diameter Flange Adaptors (BS EN 1092-1 PN25 Drilling)

Pipe OD (mm)	Pipe Material	Flange Drilling BS EN 1092-1		Tolerance on Pipe OD for Distance L		Gasket Mould No.	No. Notches In End Ring If Required	Flange Adaptor Section Type		Flange Adaptor Studs No. x Dia	Weight (kg)		Dimensions						Flange Adaptor Studs Length	
		Nominal	Drilling	(mm) +	(mm) -			Standard Sleeve	Long Sleeve		Standard Sleeve	Long Sleeve	Diameter A (mm)	Flange OD A1 (mm)	Flange Thickness T (mm)	Flange Bolts No. x Dia	Overall C Standard Sleeve (mm)	Overall C Long Sleeve (mm)	Standard Sleeve	Long Sleeve
355.6	Steel	350	PN25	1.6	1.6	J51LS	Not Rqd.	L02	L03	8 x M12	34.4	37.8	446	555	25	16 x M30	155	195	140	180
358.6	Coated Steel	350	PN25	1.6	1.6	J51LS	Not Rqd.	L02	L03	8 x M12	34.1	37.5	450	555	25	16 x M30	155	195	140	180
378	Ductile Iron	350	PN25	2.7	3.5	J52LS	8	L02	L03	8 x M12	32.2	35.8	469	555	25	16 x M30	155	195	140	180
406.4	Steel	400	PN25	1.6	1.6	J53LS	Not Rqd.	L02	L03	8 x M12	40.7	44.6	497	620	25	16 x M33	155	195	140	180
409.4	Coated Steel	400	PN25	1.6	1.6	J53LS	Not Rqd.	L02	L03	8 x M12	40.4	44.3	500	620	25	16 x M33	155	195	140	180
429	Ductile Iron	400	PN25	2.8	4.0	J54LS	8	L02	L03	8 x M12	38.2	42.3	520	620	25	16 x M33	155	195	140	180
457	Steel	450	PN25	1.6	1.6	J55LS	Not Rqd.	L02	L03	10 x M12	44.4	48.8	548	670	25	20 x M33	155	195	140	180
460	Coated Steel	450	PN25	1.6	1.6	J55LS	Not Rqd.	L02	L03	10 x M12	44.1	48.4	551	670	25	20 x M33	155	195	140	180
480	Ductile Iron	450	PN25	2.9	4.0	J56LS	10	L02	L03	10 x M12	41.4	46.0	571	670	25	20 x M33	155	195	140	180
508	Steel	500	PN25	1.6	1.6	J57LS	Not Rqd.	L02	L03	10 x M12	50.9	55.7	598	730	25	20 x M33	155	195	140	180
511	Coated Steel	500	PN25	1.6	1.6	J57LS	Not Rqd.	L02	L03	10 x M12	50.4	55.3	602	730	25	20 x M33	155	195	140	180
532	Ductile Iron	500	PN25	3.0	4.0	J58LS	10	L02	L03	10 x M12	47.4	52.4	624	730	25	20 x M33	155	195	140	180
610	Steel	600	PN25	1.6	1.6	J60LS	Not Rqd.	L02	L03	10 x M12	62.7	68.4	700	845	25	20 x M36	155	195	140	180
613	Coated Steel	600	PN25	1.6	1.6	J60LS	Not Rqd.	L02	L03	10 x M12	62.2	67.9	703	845	25	20 x M36	155	195	140	180
635	Ductile Iron	600	PN25	3.2	4.5	J61LS	10	L02	L03	10 x M12	58.3	64.2	726	845	25	20 x M36	155	195	140	180
711	Steel	700	PN25	1.6	1.6	J63LS	Not Rqd.	L02	L03	12 x M12	74.2	81.0	802	960	25	24 x M39	155	195	140	180
714	Coated Steel	700	PN25	1.6	1.6	J63LS	Not Rqd.	L02	L03	12 x M12	69.4	76.1	805	960	25	24 x M39	155	195	140	180
738	Ductile Iron	700	PN25	3.4	4.5	J63LS	12	YF2	YF3	12 x M16	82.5	90.0	849	960	25	24 x M39	169	195	160	190
813	Steel	800	PN25	1.6	1.6	J65LS	Not Rqd.	YF2	YF3	12 x M16	106.5	113.6	922	1085	25	24 x M45	169	199	160	190
816	Coated Steel	800	PN25	1.6	1.6	J65LS	Not Rqd.	YF2	YF3	12 x M16	83.8	113.0	906	1085	25	24 x M45	169	199	160	190
842	Ductile Iron	800	PN25	1.0	4.5	J65LS	12	YF2	YF3	12 x M16	100.0	107.5	950	1085	25	24 x M45	169	199	160	190
914	Steel	900	PN25	1.6	1.6	J117M	7	A2E	A2H	14 x M16	168.6	137.1	1038	1185	38	28 x M45	182	212	160	190
916	Coated Steel	900	PN25	1.6	1.6	J117M	7	A2E	A2H	14 x M16	167.9	136.3	1041	1185	38	28 x M45	182	212	160	190
945	Ductile Iron	900	PN25	1.0	5.0	J118M	14	A2E	A2H	14 x M16	156.1	124.0	1069	1185	38	28 x M45	182	212	160	190

Every effort has been made to ensure that the information contained in this publication is accurate at the time of publishing. Crane Ltd assumes no responsibility or liability for typographical errors or omissions or for any misinterpretation of the information within the publication and reserves the right to change without notice.

DR10998_01_10_2024_ISSUE 8

Technical Information

Viking Johnson manufacture flange adaptors to any pipe OD and flange drilling. If the product required is not shown in any of our tables please contact Viking Johnson who can provide the relevant information.

Working Pressure Rating

For Water / Wastewater applications in accordance with flange rating.

Gas 6 bar

Vacuum Pressure

Capable of accommodating a vacuum pressure of -0.7 bar

Site Test Pressure

1.5 times working pressure for short duration (2 hours)

End Load Due to Internal Pressure

Dedicated Flange Adaptors DO NOT resist end load due to the internal pressure - adequate external restraint must be provided to prevent pipe pull out from the coupling.

Tie Rods

When using tie rods to provide restraint, depending on the pipe OD & flange drilling the flange adaptor end ring may need to be notched to allow the tie rod to pass over.

The Large Diameter Flange Adaptor Technical Data (BS EN 1092-1 PN25 Drilling) Table provides details on:

- Those products that do not require notching (i.e. there is no interference between the tie rods and end ring) - indicated by "Not Rqd."
- Those products where there is interference between the tie rod and end ring and do require notching, with the number of notches provided as standard indicated.

Materials & Relevant Standards

Flange Body & End Ring

Steel to BS EN10025-2: Grade S275JR

Gaskets: L02/L03/YF2/YF3

Rubber 80 IRHD Moulded Compound to BS EN681-1: Type WA,WC,WG

BS EN682: Type G

(other materials available on request)

Gaskets: A2E/A2H/XSXG

Rubber 70 IRHD Moulded Compound to BS EN681-1: Type WA, WC, WG

BS EN682: Type G

(other materials available on request)

Tie Rod Yield Strength

The number of notches indicated assumes the use of tie rods with a minimum yield strength of 725 N/mm².

If tie rods with a lower yield strength are used, then depending on the working pressure an increased number than that specified in the table may be required; in this situation please advise Viking Johnson of the number of notches and we will accommodate your requirements.

Temperature Rating of Product

EPDM -20°C to +90°C

Nitrile -20°C to +90°C

Other Gasket Grades Contact Viking Johnson.

For use on applications with fluctuating and / or elevated temperatures (> 60°C) may require regular maintenance to re-tighten the bolts and must be included in any maintenance schedule.

Approvals

The following water contact materials used in Large Diameter Dedicated products are approved for use with potable water:-

Rilsan Nylon 11:

- WRAS, DVGW, W270, ACS & KIWA.

EPDM Gaskets:

- WRAS

In addition to the above, Large Diameter Dedicated range as a finished product has KIWA certification verifying that the above products comply with the requirements of the Water Supply (Water Fittings) Regulations for England and Wales 1999, the Water Byelaws 2000, Scotland and the Water Regulations Northern Ireland.

Coatings

Body, Flange & End Ring:

- Rilsan Nylon 11 to WIS 4-52-01 Part 1

Nuts & Studs:

- Sheraplex coated to WIS 4-52-03

Studs

Steel to BS EN ISO898-1: Property Class 4.8

Nuts

Steel to BS4190: Grade 4

Washers

Stainless Steel to BS1449:Part 2: Grade 304S15