

Universal EasiTee

Datasheet 1/2

Universal EasiTee

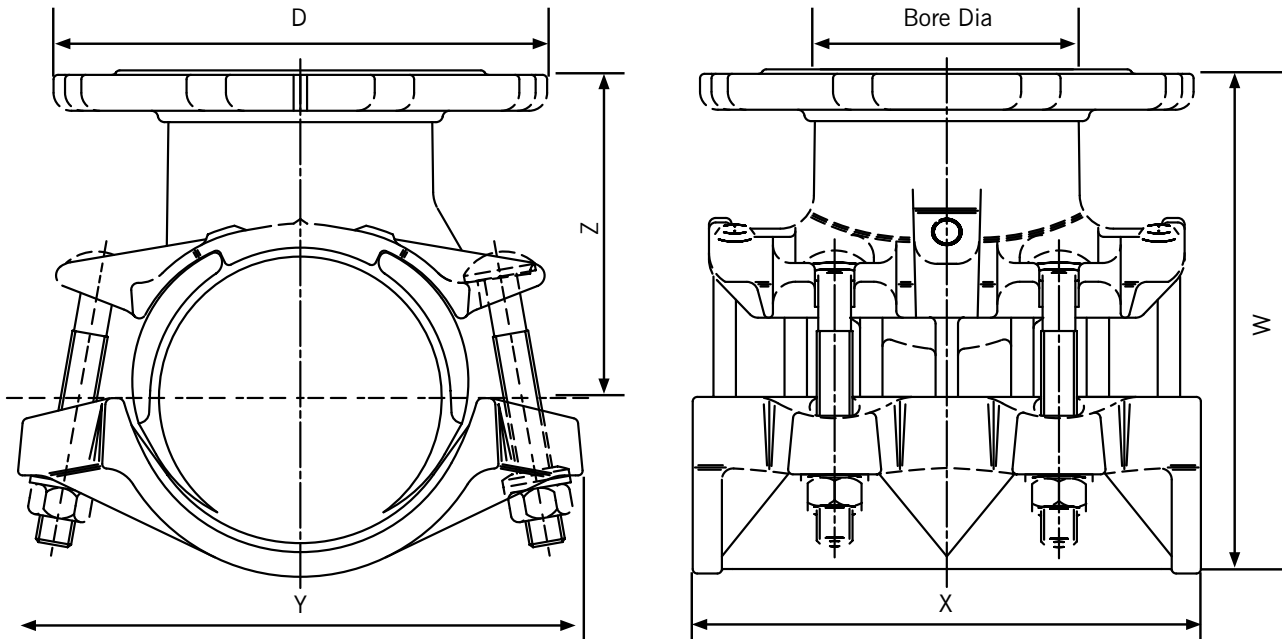

Universal EasiTee

Pipe OD Size Range (mm)		Branch Drilling		Plain Mould No.	Branch Mould No.	Dimensions (mm)					Minimum Bore Dia (mm)	Bolt Size No.-Size x length	Weight (kg)
Min	Max	Nom	Spec			D	W	X	Y	Z			
85.4	103.0	80	PN 10,16	1792	1791	200	205	213	193	128	76.0	4-M16 x 110	9.0
111.8	129.4	80/100	PN 10,16	1741	1740	200	228	227	252	146	103.0	4-M16 x 130	10.5
165.2	184.4	80/100	PN 10,16	1743	1742	200	275	269	305	165	103.0	4-M16 x 130	18.7
165.2	184.4	150	PN 10,16	1743	1742	285	275	269	305	165	153.0	4-M16 x 130	20.9
215.9	239.7	80/100	PN 10,16	1745	1744	200	365	319	385	228	103.0	6-M20 x 140	25.4
215.9	239.7	150	PN 10,16	1745	1744	285	365	319	385	228	154.0	6-M20 x 140	28.0
215.9	239.7	200	PN 16	1745	1744	340	365	319	385	228	205.0	6-M20 x 140	29.5
269.2	293.5	80/100	PN 10,16	1747	1746	200	424	368	462	260	103.0	6-M20 x 140	49.1
269.2	293.5	150	PN 10,16	1747	1746	285	424	368	462	260	154.0	6-M20 x 140	51.2
269.2	293.5	200	PN 16	1747	1746	340	424	368	462	260	206.0	6-M20 x 140	52.3
269.2	293.5	250	PN 16	1747	1746	405	424	368	462	260	256.0	6-M20 x 140	56.6
323.1	349.0	80/100	PN 10,16	1749	1748	200	478	439	534	290	103.0	6-M24 x 160	58.7
323.1	349.0	150	PN 10,16	1749	1748	285	478	439	534	290	154.0	6-M24 x 160	61.0
323.1	349.0	200	PN 16	1749	1748	340	478	439	534	290	205.0	6-M24 x 160	62.5
323.1	349.0	250	PN 16	1749	1748	405	478	439	534	290	255.0	6-M24 x 160	66.0
323.1	349.0	300	PN 16	1749	1748	460	478	439	534	290	304.0	6-M24 x 160	66.0

Every effort has been made to ensure that the information contained in this publication is accurate at the time of publishing. Crane Ltd assumes no responsibility or liability for typographical errors or omissions or for any misinterpretation of the information within the publication and reserves the right to change without notice.

DR10998_01_10_2024_ISSUE 8

Technical Information

Working Pressure Rating

Water 16 bar

Gas not approved

Vacuum Pressure

Capable of accommodating a vacuum pressure of -0.7 bar

Site Test Pressure

1.5 times working pressure for short duration (2 hours)

Angularity

Universal EasiTee fittings are not able to accommodate any angularity.

Bolt Torque/Spanner:

M16; Torque 95-110Nm on every bolt

Spanner size A/F 24mm

M20; Torque 150-165Nm on every bolt

Spanner size A/F 30mm

M24; Torque 285-300Nm on every bolt

Spanner size A/F 36mm

Temperature Rating of Product

EPDM -20°C to +40°C

Universal EasiTee is not suitable for use on heating systems with fluctuating temperatures.

Loads from Drilling Equipment and Valve / Branch Pipework

Universal EasiTee is not designed to accommodate / resist the loads from the under pressure drilling equipment, which needs to be supported externally during the operation to drill into the main. In addition, the valve and branch pipework needs to be adequately supported to ensure none of the dead / live loads are imposed in the branch outlet in the Universal EasiTee.

Approvals

The following water contact materials used in Universal EasiTee are approved for use with potable water:-

Rilsan Nylon 11:

➤ WRAS, DVGW, W270, ACS & KIWA

EPDM Gaskets:

➤ WRAS

In addition to the above, Universal EasiTee as a finished product has KIWA certification verifying that the above products comply with the requirements of the Water Supply (Water Fittings) Regulations for England and Wales 1999, the Water Byelaws 2000, Scotland and the Water Regulations Northern Ireland.

Materials & Relevant Standards

Housing

Flanged Housing:

➤ Ductile Iron to BS EN1563 SYMBOL EN-GJS-450-10

Plain Housing:

➤ Ductile Iron to BS EN1563 SYMBOL EN-GJS-450-10

Bridging Plate

Ductile Iron to BS EN1563 SYMBOL EN-GJS-450-10

Gasket

BS EN681-1 60 IRHD

Coatings

Flanged, Plain Housing & Bridging Plate:

➤ Rilsan Nylon 11 to WIS 4-52-01 (Part1)

Bolts & Nuts (standard Option):

➤ Flurene coated

Bolts

Steel to BS EN ISO 898-1 Property Class 4.8 or

Steel to BS EN 10083: Part 1 Grade 2.C.22

Nuts

Steel to BS 4190 Grade 4

Spherical Washers

Pearlite Malleable Iron to BS EN 1562 Symbol EN-GJMW-400-5

Washers

Stainless Steel to BS 1449: Part 2 Grade 304 S15