

MaxiFit Large Diameter Couplings

Datasheet 1/2

Coupling

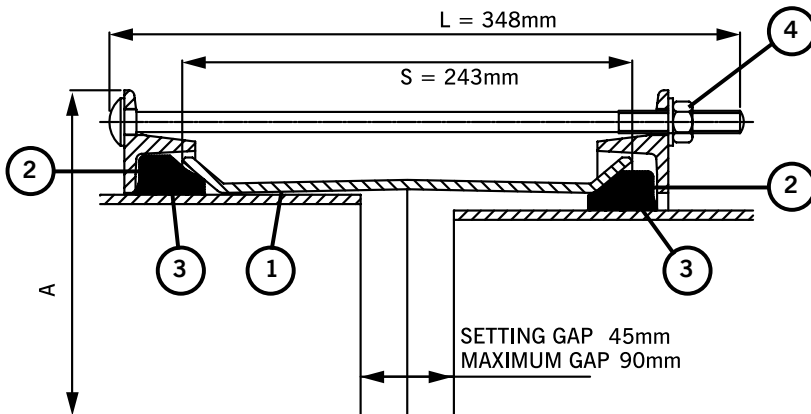

Key

- 1 = Sleeve
- 2 = End Ring
- 3 = Gasket
- 4 = Bolts, Nut & Washer

MaxiFit Large Diameter Couplings

| OD Range | | Dimensions | Gasket Mould No. | Bolts No.-Dia x Length | Weight (kg) |
|----------|----------|--------------------------|------------------|------------------------|-------------|
| Min (mm) | Max (mm) | End Ring Diameter A (mm) | | | |
| 351.0 | 368.0 | 478.0 | 6002 | 8-M12 x 340 | 30.1 |
| 374.5 | 391.5 | 501.5 | 1659 | 8-M12 x 340 | 31.9 |
| 386.0 | 403.0 | 513.0 | 6035 | 8-M12 x 340 | 32.6 |
| 394.3 | 411.3 | 521.5 | 1766 | 8-M12 x 340 | 33.2 |
| 404.8 | 421.8 | 532.0 | 1767 | 8-M12 x 340 | 34.0 |
| 412.0 | 429.0 | 539.0 | 6023 | 10-M12 x 340 | 35.1 |
| 418.2 | 435.2 | 545.0 | 1784 | 8-M12 x 340 | 34.9 |
| 425.0 | 442.0 | 552.0 | 1662 | 8-M12 x 340 | 35.5 |
| 434.5 | 451.5 | 561.5 | 1768 | 10-M12 x 340 | 37.0 |
| 439.0 | 456.0 | 566.0 | 6036 | 10-M12 x 340 | 37.3 |
| 447.2 | 464.2 | 574.0 | 1769 | 10-M12 x 340 | 37.9 |
| 455.0 | 472.0 | 582.0 | 6003 | 10-M12 x 340 | 38.5 |
| 467.0 | 484.0 | 594.0 | 6073 | 10-M12 x 340 | 39.3 |
| 476.0 | 493.0 | 603.0 | 1770 | 10-M12 x 340 | 39.9 |
| 487.0 | 504.3 | 614.5 | 1771 | 10-M12 x 340 | 40.7 |
| 492.0 | 509.0 | 619.0 | 6037 | 10-M12 x 340 | 41.1 |
| 501.9 | 518.9 | 629.0 | 1772 | 10-M12 x 340 | 41.8 |
| 510.0 | 527.0 | 637.0 | 6004 | 10-M12 x 340 | 42.3 |
| 515.0 | 532.0 | 642.0 | 6024 | 10-M12 x 340 | 42.8 |
| 527.0 | 544.0 | 654.0 | 1773 | 12-M12 x 340 | 44.1 |
| 540.1 | 557.1 | 667.0 | 1774 | 10-M12 x 340 | 44.5 |
| 546.0 | 563.0 | 673.0 | 6038 | 12-M12 x 340 | 45.5 |
| 555.3 | 572.3 | 682.5 | 1775 | 12-M12 x 340 | 46.1 |
| 565.0 | 582.0 | 692.0 | 1776 | 12-M12 x 340 | 46.8 |
| 582.2 | 599.2 | 709.0 | 1777 | 12-M12 x 340 | 48.0 |
| 593.0 | 610.0 | 720.0 | 6021 | 12-M12 x 340 | 48.8 |
| 601.0 | 618.0 | 728.0 | 6020 | 12-M12 x 340 | 49.4 |
| 613.0 | 630.0 | 740.0 | 6019 | 12-M12 x 340 | 50.3 |
| 618.0 | 635.0 | 745.0 | 6025 | 12-M12 x 340 | 50.6 |
| 630.0 | 647.0 | 757.0 | 1778 | 14-M12 x 340 | 52.0 |
| 645.2 | 662.2 | 772.0 | 1779 | 14-M12 x 340 | 53.0 |
| 654.0 | 671.0 | 781.0 | 6039 | 14-M12 x 340 | 53.8 |
| 662.0 | 679.0 | 789.0 | 1780 | 14-M12 x 340 | 54.3 |
| 675.0 | 692.0 | 802.0 | 6005 | 14-M12 x 340 | 55.2 |
| 689.0 | 706.0 | 816.0 | 10511/49 | 14-M12 x 340 | 56.3 |
| 695.0 | 712.0 | 822.0 | 6063 | 14-M12 x 340 | 56.7 |
| 710.0 | 727.0 | 837.0 | 6075 | 14-M12 x 340 | 57.7 |

Every effort has been made to ensure that the information contained in this publication is accurate at the time of publishing. Crane Ltd assumes no responsibility or liability for typographical errors or omissions or for any misinterpretation of the information within the publication and reserves the right to change without notice.

DR10998_01_10_2024_ISSUE 8

MaxiFit Large Diameter Couplings

Datasheet

2/2

Technical Information

Working Pressure Rating

Water 16 bar

Gas 6 bar

Vacuum Pressure

Capable of accommodating a vacuum pressure of -0.7 bar

Site Test Pressure

1.5 times working pressure for short duration (2 hours)

Angularity

Couplings 6°

The above are for when the product is on maximum pipe outside diameters; can achieve larger ones with smaller pipe diameters.

Bolt Torque/Spanner

M12; Torque 55-65Nm on every bolt

Spanner size A/F 19mm

Temperature Rating of Product

EPDM -20°C to +90°C

Nitrile -20°C to +90°C

For use on applications with fluctuating and / or elevated temperatures (> 60°C) may require regular maintenance to re-tighten the bolts and must be included in any maintenance schedule.

End Load Due to Internal Pressure

MaxiFit DOES NOT resist end load due to the internal pressure - adequate external restraint must be provided to prevent pipe pull out.

Approvals

The following water contact materials used in MaxiFit are approved for use with potable water:-

Rilsan Nylon 11:

➤ WRAS, DVGW, W270, ACS & KIWA

EPDM Gaskets:

➤ WRAS

In addition to the above, MaxiFit range as a finished product has KIWA certification verifying that the above products comply with the requirements of the Water Supply (Water Fittings) Regulations for England and Wales 1999, the Water Byelaws 2000, Scotland and the Water Regulations Northern Ireland.

Materials & Relevant Standards

Sleeve

Rolled Steel to BS EN 10025-2 Grade S275

End Ring

Rolled Steel to BS EN 10025-2 Grade S275

Gasket

EPDM Grade "E" to BS EN 681-1 Type WA WRAS Listed

Nitrile compound to Grade G BS EN 682, Type G

Coating

Sleeve & End Ring:

➤ Rilsan Nylon 11 to WIS 4-52-01 Part 1

Bolts & Nuts:

➤ Sheraplex to WIS 4-52-03

Bolts

Standard - Steel to BS EN ISO 898-1 Property Class 4.8

Option - Stainless Steel to BS EN ISO 3506-1: grade A4 property class 50

Nuts

Standard - Steel to BS EN 4190 Grade 4

Option - Stainless Steel to BS EN ISO 3506-2: grade A4 property class 80

Washers

Stainless Steel to BS 1449:Part 2 Grade 304 S15

Every effort has been made to ensure that the information contained in this publication is accurate at the time of publishing. Crane Ltd assumes no responsibility or liability for typographical errors or omissions or for any misinterpretation of the information within the publication and reserves the right to change without notice.

DR10998_01_10_2024_ISSUE 8