

MaxiFit Plus Couplings, Flange Adaptors & End Caps

Datasheet 1/2

Coupling

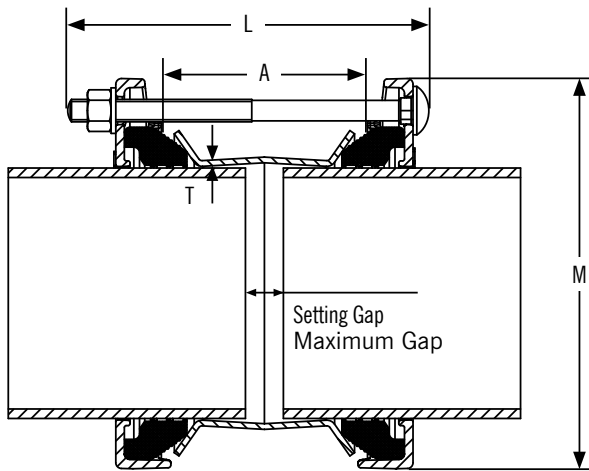

Flange Adaptor

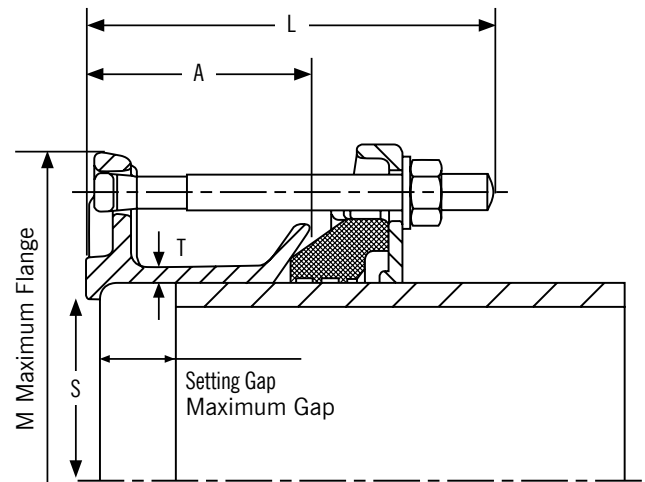

MaxiFit Plus Couplings & End Caps

Nominal Size (mm)	Size Range (mm)		Diameter (mm) M	Overall Length (mm) L	Sleeve Length x Thickness (A) x (T)	Sleeve	Setting Gap (mm)		Bolts No-Dia X Length	Gasket Mould	Weight (kg)	MaxiCap Available
	Min	Max					Min	Max				
DN50	57	74	154.5	190	95 x 3	Steel	20	40	4-M12 x 180	12392/1	2.7	✓
DN65	63	85	173.5	190	95 x 4.5	Ductile Iron	20	40	3-M12 x 180	12392/2	3.6	✓
DN65	63	85	173.5	190	95 x 3	Steel	20	40	3-M12 x 180	12392/2	3.2	✓
DN80	85	107	195.5	190	95 x 4.5	Ductile Iron	20	40	3-M12 x 180	12392/3	4.1	✓
DN80	85	107	195.5	190	95 x 3	Steel	20	40	3-M12 x 180	12392/3	3.7	✓
DN100	107	132	224.5	190	95 x 4.5	Ductile Iron	20	40	3-M12 x 180	12392/4	5.0	✓
DN100	107	132	224.5	190	95 x 3	Steel	20	40	3-M12 x 180	12392/4	4.5	✓
DN125	132	158	254.5	190	95 x 3	Steel	20	40	4-M12 x 180	12392/6	5.2	✓
DN150	158	184	280.5	190	95 x 3	Steel	20	40	4-M12 x 180	12392/7	6	✓

For other sizes of coupling, please see MaxiFit Coupling Datasheets.

MaxiFit Plus Flange Adaptors

Nominal Size (mm)	Size Range (mm)		Diameter (mm) M	Bore (mm) S	Overall Length (mm) L	Sleeve Length x Thickness (A) x (T)	Flange Drilling Options				Setting Gap (mm)		Bolts No-Dia X Length	Gasket Mould	Weight (kg)
	Min	Max					Nom (DN)	Metric Drilling Specification	Nom (Inches)	Imperial Drilling Specification	Min	Max			
DN65	63	85	196.9	75	124	75 x 5	60	PN10 / 16	2.5"	ANSI 125/150	20	40	3-M12 x 115	12392/2	3.6
							65	PN10 / 16	3"	BS10 Table ADE ANSI 125/150					
							80	PN10 / 16 AS2129 CD AS4087 16							
DN80	85	107	202.5	101	124	75 x 5	80	PN10 / 16	3"	ANSI 125/150	20	40	3-M12 x 115	12392/3	3.8
									3.5"	BS10 Table ADE					
DN100	107	132	228	121	134	75 x 5	100	PN10 / 16 AS2129 CD AS4087 16	4"	BS10 Table ADE AWWA C207 D ANSI 125/150	20	40	3-M12 x 125	12392/4	4.7

For other sizes of flange adaptors, please see MaxiDaptor Datasheets.

Every effort has been made to ensure that the information contained in this publication is accurate at the time of publishing. Crane Ltd assumes no responsibility or liability for typographical errors or omissions or for any misinterpretation of the information within the publication and reserves the right to change without notice.

DR10998_01_10_2024_ISSUE 8

MaxiFit *Plus* Couplings, Flange Adaptors & End Caps

Datasheet

2/2

Technical Information

Working Pressure Rating

Water 16 bar

Gas 6 bar

Vacuum Pressure

Capable of accommodating a vacuum pressure of -0.8 bar to EN 14525

Site Test Pressure

1.5 times working pressure for short duration (2 hours)

Flange Drilling & Pressure Rating

While drilling patterns defined for the flange adaptors are compatible with the standards listed in the data sheet table, the rated working pressure of the product is as noted above.

Angularity

Couplings 6°

Flange Adaptors 3°

The above are for when the product is on maximum pipe outside diameters; can achieve larger ones with smaller pipe diameters.

Bolt Torque/Spanner

M12; Torque 55-65Nm on every bolt

Spanner size A/F 19mm

Temperature Rating of Product

EPDM -20°C to +90°C

Nitrile -20°C to +90°C

For use on applications with fluctuating and / or elevated temperatures (> 60°C) may require regular maintenance to re-tighten the bolts and must be included in any maintenance schedule.

End Load Due to Internal Pressure

MaxiFit DOES NOT resist end load due to the internal pressure - adequate external restraint must be provided to prevent pipe pull out.

Approvals

The following water contact materials used in MaxiFit are approved for use with potable water:-

Rilsan Nylon 11

➤ WRAS, DVGW, W270, ACS & KIWA

EPDM Gaskets

➤ WRAS

In addition to the above, MaxiFit range as a finished product has KIWA certification verifying that the above products comply with the requirements of the Water Supply (Water Fittings) Regulations for England and Wales 1999, the Water Byelaws 2000, Scotland and the Water Regulations Northern Ireland.

DN40 to DN300 MaxiFit has been independently tested by BSI to confirm it meets the requirements of BS EN 14525

Materials & Relevant Standards

End Ring and Adaptor Body

Ductile Iron to BS EN 1563 Symbol EN GJS-450-10

Centre Sleeve

Sleeve material is rolled Steel to BS EN10025-2 grade S275 or Ductile Iron to BS EN1563 symbol EN GJS-450-10

Gasket

EPDM compound Grade E to BS EN 681-1, Type WA, WC

Nitrile compound to Grade G BS EN 682, Type G

Coating

Sleeve, Adaptor Body & End Ring:

➤ Rilsan Nylon 11 to WIS 4-52-01 Part 1

Bolts & Nuts:

➤ Sheraplex to WIS 4-52-03

Tee Bolts/Bolts

Standard - Steel to BS EN ISO 898-1 Property Class 4.8

Option - Stainless Steel to BS EN ISO 3506-1: grade A4 property class 50

Nuts

Standard - Steel to BS EN 4190 Grade 4

Option - Stainless Steel to BS EN ISO 3506-2: grade A4 property class 80

Washers

Stainless Steel to BS 1449:Part 2 Grade 304 S15