

UltraGrip Couplings

Datasheet 1/2

Coupling

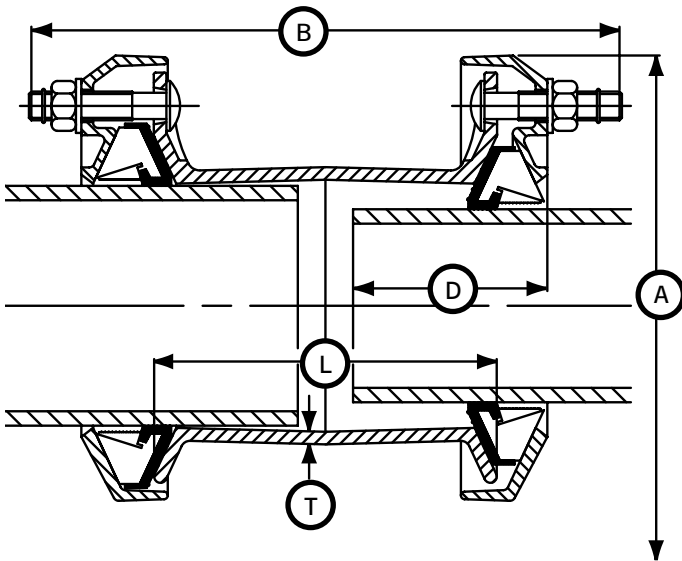

UltraGrip Couplings

Nom Size	Size Range		Insertion Depth (D)		Dimensions				Bolts		Weight (kg)
	Min	Max	Min	Max	Overall		Sleeve		No-size	Type	
40	43.5	63.5	65	95	168	262	144	7.0	6-M12 x 70	HRH	5.76
50	48.0	71.0	65	110	178	296	180	5.0	6-M12 x 70	CSX	6.13
65	63.0	83.7	65	95	189	262	144	7.0	6-M12 x 70	HRH	6.86
80	85.7	107.0	65	110	212	288	170	7.0	6-M12 x 70	HRH	8.54
100	107.0	133.2	90	125	280	342	180	7.0	6-M16 x 93	CSX	13.57
125	132.2	160.2	90	125	305	342	180	6.0	6-M16 x 93	CSX	14.51
150	158.2	192.2	90	135	339	386	213	6.5	8-M16 x 93	CSX	20.22
175	192.2	226.9	125	165	403	400	220	6.5	10-M16 x 93	CSX	33.22
200	218.1	256.0	125	165	432	400	220	6.5	10-M16 x 93	CSX	35.48
250	266.0	310.0	125	165	476	524	300	8.0	12-M16 x 120	CSX	52.88
300	315.0	356.0	125	200	522	524	300	8.0	16-M16 x 120	CSX	63.8
350	352.2	396.0	125	200	577	525	300	7.5	18-M16 x 120	CSX	74.58
400	398.2	442.0	125	200	623	525	300	7.5	20-M16 x 120	CSX	82.88
450	448.0	492.0	135	215	713	545	300	7.5	24-M16 x 140	HRH	139.03
500	498.0	552.0	155	215	803	565	300	7.5	18-M20 x 150	HRH	160.42
500	558.0	608.0	155	215	860	565	300	7.5	20-M20 x 150	HRH	175.02
600	604.0	648.0	195	255	900	565	300	7.5	24-M20 x 150	HRH	240.01
600	676.0	726.0	195	255	975	565	300	7.5	28-M20 x 150	HRH	267.38

Working Pressure & Temperature Ratings

Nominal Size	Gripping Product		Flex Product		Operating Temperature
	Gas	Water	Gas	Water	
DN40 to DN300	5 bar	16 bar	5 bar	16 bar	-20°C to +30°C
DN350 to DN400	5 bar	10 bar	5 bar	10 bar	
DN450 to DN600	N/A	10 bar	N/A	10 bar	

Notes:

- 1) Site Test Pressure – 1.5 times working pressure.
- 2) Factory Test Pressure – The minimum requirement in European Standards is 1.5 times working pressure plus 5 bar (e.g. 29 bar for 16 bar working pressure).
- 3) All water contact components are approved for use with Potable Water.

Bolt Torque	
	Nm
M12	55 - 70
M16	95 - 120
M20	210 - 230

Every effort has been made to ensure that the information contained in this publication is accurate at the time of publishing. Crane Ltd assumes no responsibility or liability for typographical errors or omissions or for any misinterpretation of the information within the publication and reserves the right to change without notice.

Technical Information

Gripping product suitable for

Steel / Ductile iron / Grey cast iron / PE / PVC

Flex product suitable for

Steel / Ductile iron / Grey cast iron / PVC / Asbestos cement

Angularity

Couplings 8°

Support liners – PE and PVC pipes

A close fit support liner is required when used on:

- ▶ All PE pipes
- ▶ Thin walled PVC pipes

When used on thick walled PVC pipes a support liner is not required. Please contact Viking Johnson for further details.

Use of restrained couplings on exposed pipework

Above ground exposed pipework is subject to both loads from the internal pressure and those from temperature changes / thermal expansion, which can be substantially higher than those from internal pressure and cannot always be safely determined. For this reason it is recommended that the use of UltraGrip be restricted to buried pipelines, valve chambers and above ground indoor applications and not exposed to direct sunlight or excessive temperature changes (e.g. pump houses).

Approvals

The following water contact materials used in UltraGrip are approved for use with potable water:-

Rilsan Nylon 11:

- ▶ WRAS, KIWA

Gasket (EPDM):

- ▶ WRAS, KTW, DVGW, W270, KIWA

In addition to the above, UltraGrip range as a finished product has KIWA certification verifying that the above products comply with the requirements of the Water Supply (Water Fittings) Regulations for England and Wales 1999, the Water Byelaws 2000, Scotland and the Water Regulations Northern Ireland.

Gasket (Nitrile):

- ▶ DVGW Approved

DN40 to DN300 UltraGrip has been independently tested by BSI to confirm it meets the requirements of BS EN 14525.

Materials & Relevant Standards

End Rings & Centre Sleeve

S.G. Iron to BS EN 1563 Symbol EN-GJS-450-10

Gasket

EPDM Compound Grade E to BS EN 681-1

Nitrile Compound to Grade G BS EN 682, Type G

Gripper & Carrier

Acetal Copolymer Grade M25 or equivalent

Coatings

Cast/Metal Components:

- ▶ Rilsan Nylon 11 (Black)

Bolts:

- ▶ Delta Seal GZ - Silver

Nuts:

- ▶ Delta Seal GZ - Silver

Bolts

Standard - Stainless steel to BS EN 3506-1 Grade A2 Property Class 80 or 70

Option - Stainless steel to BS EN ISO 3506-1 Grade A4 Property Class 50

Nuts

Stainless Steel to BS EN 3506-2 Grade A4 Property Class 80

Washers

Stainless steel – BS1449:PT2 Grade 304 S15

Grit to Gripper

Corundum - aluminium oxide with a chemical composition of Al_2O_3 and a hexagonal crystal structure (rock-forming mineral that is found in igneous, metamorphic, and sedimentary rocks).