

WallCouplings™

Specialist Through Wall Connections

Easy Installation Eliminates Boxing Out Process

 **VIKING JOHNSON®**

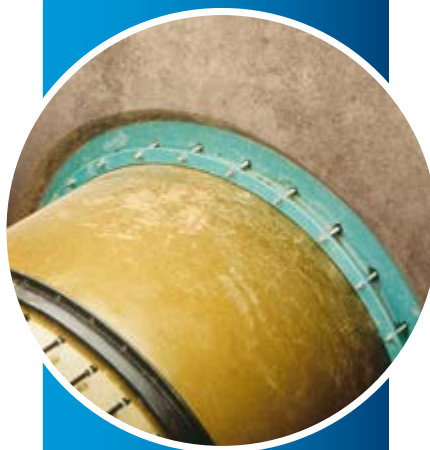



The Perfect Solution for Passing Pipes Through Walls

Old Practice

The normal procedure for passing pipes through walls is to leave a substantial cut-out in the wall during the original concrete pouring process. Later, the contractor will pass a 'puddle pipe' through the cut-out, and build an intricate 'letter-box' shutter around it. New concrete is then poured into the void to encapsulate the puddle pipe. Not only is this a time consuming process, but very often the puddle pipe moves with the pour and settles to a less than suitable alignment.



Easier Installation

By utilising a Viking Johnson wall coupling which is held rigidly between the shutters, the 'boxing out' process is eliminated. This means that pouring the wall is a simplified and is a single step process. It also guarantees that leak paths, which are inevitably set up when new concrete is poured onto old, are completely eliminated.

Using a standard Type 1 Viking Johnson wall coupling gives a versatile coupling either side of the wall where pipes can either be passed through or inserted into each side. This system allows for misalignment or angular deflection of up to 3° on each side of the wall. In addition, the use of a Viking Johnson wall coupling ensures that, on the outside of the structure, the first 'rocker' or settlement coupling is built into the shear face of the wall – exactly where it is required. It also means that only one further versatile coupling is needed to form the settlement 'rocker' instead of two. Consequently the installed cost can be drastically reduced, particularly where a large number of through the wall joints appear on a building, for instance in a gravity treatment works.

Structural Strength of Concrete Wall

Viking Johnson strongly recommends the user ensures that the wall is structurally capable of withstanding the resultant forces induced by the system working pressure and any other related influence.

Wall Couplings - Type 1

Product Design Benefits

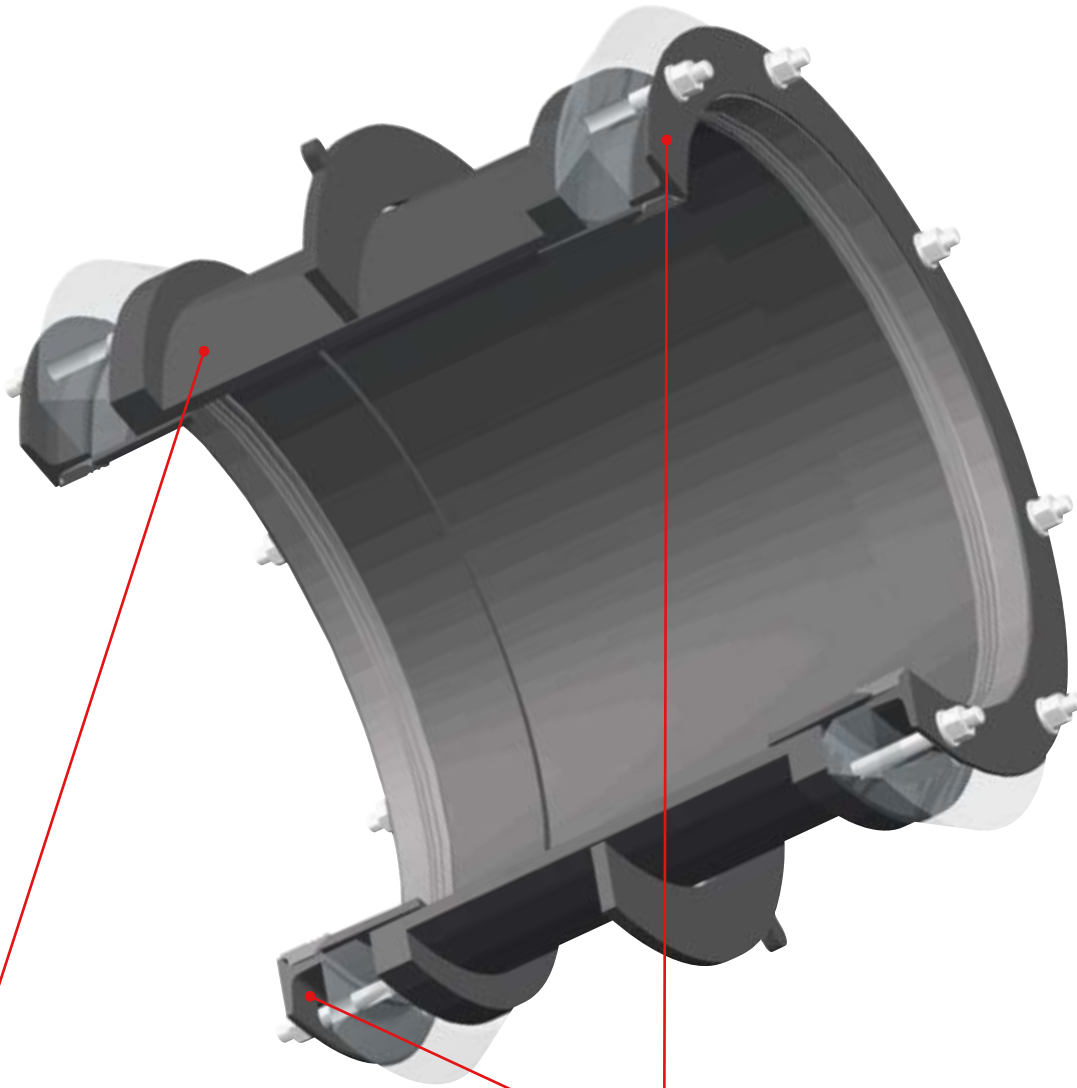

■ Corrosion Protection

Metal components are coated with Rilsan Nylon 11 which is WRAS approved for use with potable water and offers a long term protection to corrosion, impact and abrasion to ensures continued reliable performance.

■ Flexible Fit

Using a standard Type 1 Viking Johnson wall coupling gives a flexible coupling either side of the wall where pipes can either be passed through or inserted into each side. This allows for slight misalignment or angular deflection on each side of the wall.

Customer Benefits

- ▶ Straightforward for Civil Contractor to position the pipe.
- ▶ Easy to secure and prevent movement of the pipe work.
- ▶ Large formwork panels can be reused as there is no need to make holes in the shuttering.
- ▶ No need for a contractor to come back and cast in pipes or 'make good' the wall surface after casting pipes.
- ▶ Ensures good bond between wall and pipe.
- ▶ Installed cost can be drastically reduced particularly where a large number of through the wall joints appear on a structure e.g. in a gravity treatment works.

Wall Couplings - Type 1

Installation Benefits

Conventional Method with a Puddle Pipe

In civil projects with reinforced concrete work & pipework it is inevitable that there will be a need to pass a pipe through a concrete wall.

Traditional methods to accommodate pipework are:-

- Box Out a section and come back later to cast in pipe.
- Cast In the Puddle Pipe, by cutting the formwork to include the pipe when pouring main wall.

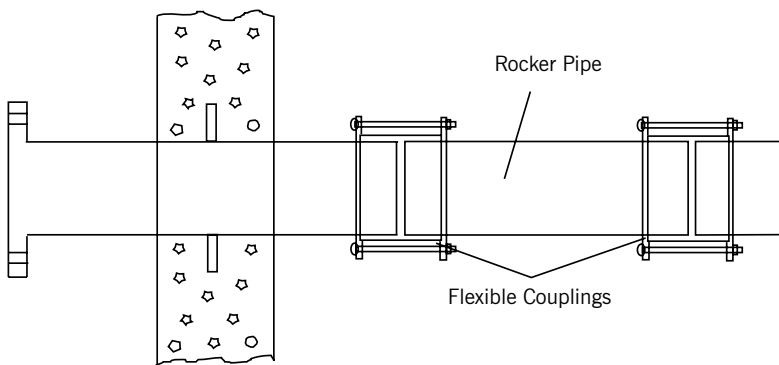

Viking Johnson Wall Coupling Method

Designed to fit flush between formwork panels and coming with various end configurations to accommodate site conditions, Viking Johnson Wall Couplings provide an alternative means of passing a pipe through a wall or slab, that also offers the following advantages.

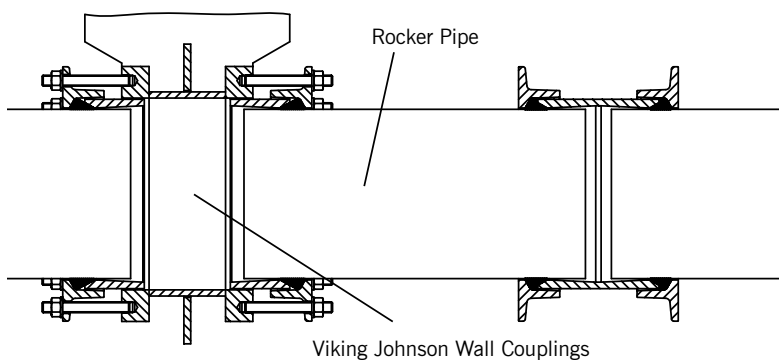

Traditional Methods Disadvantages:

Boxing Out

- Make up formwork for box out that will only have one use.
- Never get a good surface finish between old and new concrete.
- Potential weak joint between old and new concrete.

Casting In

- Civil contractor has to position pipe at correct level and location in wall.
- When pouring large walls there is always a risk of movement of formwork and therefore cannot always get pipework accurately positioned.
- Formwork can only be used for one concrete pour.

In addition to the problems with casting in the puddle pipe, two flexible couplings are required along with a rocker pipe to accommodate ground movement.

Wall Coupling Advantages:

- Easier for civil contractor to position pipe at correct level & location in wall.
- Easier to secure wall coupling to prevent risk of movement during pouring of concrete.
- Large formwork panels can be re-used.
- No need to come back to wall to cast in pipes.
- No need to "make good" wall surface after pouring secondary concrete around pipe.

In addition, the use of a Viking Johnson wall coupling ensures that, on the outside of the structure, the first 'rocker' or settlement coupling is built into the shear face of the wall – exactly where it is required. It also means that only one further versatile coupling is needed to form the settlement 'rocker' instead of two.

Every effort has been made to ensure that the information contained in this publication is accurate at the time of publishing. Crane Ltd assumes no responsibility or liability for typographical errors or omissions or for any misinterpretation of the information within the publication and reserves the right to change without notice.

Wall Coupling Variations

Datasheet

1/1

The Viking Johnson Wall Coupling is available in nine variations:

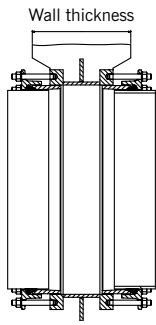

Type 1 Coupling / Coupling

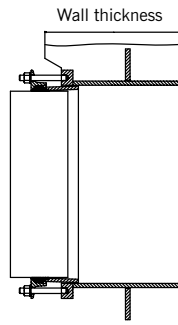

Type 2 Coupling / Plain End

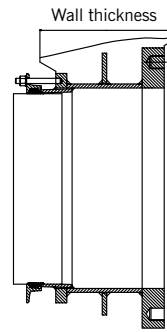

Type 3 Coupling / Flange

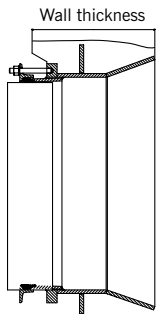

Type 4 Coupling / Bellmouth

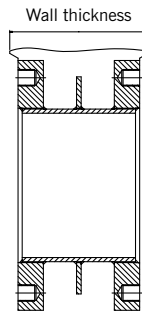

Type 5 Flange / Flange

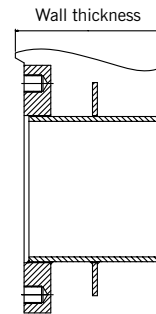

Type 6 Flange / Plain End

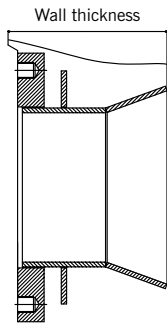

Type 7 Flange / Bellmouth

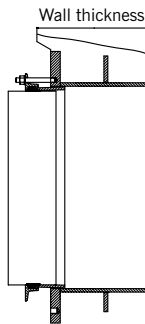

Type 8 Harnessing

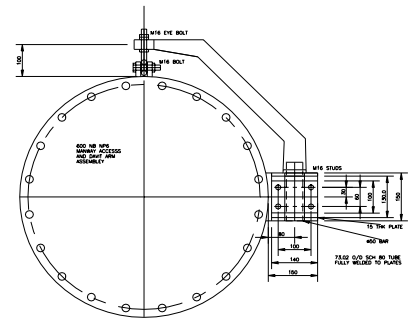

Type 9 Man Entry

Viking Johnson Wall Couplings are patented products - UK Patent No. 2263323B, US Patent No.5505499.

Materials, Relevant Standards & Approvals

Body, Centre Sleeve & End Rings:

DN80 to DN300:

- ▶ Carbon steel to BS EN 10025: Grade S275JR
- ▶ Ductile iron to BS EN 1563: Symbol EN-GJS-450-10

DN350 to DN1800:

- ▶ Carbon steel to BS EN 10025: Grade S275JR

Gasket

EPDM to BS EN 681 Part 1 Type WA

Coatings

Wall Coupling Bodies & End Rings:

- ▶ Standard Rilsan Nylon 11.
- ▶ Optional - Scotchkote 206N fusion bonded epoxy.

Studs:

- ▶ Sheraplex coated to WIS 4-52-03.

Tee Bolts or Stud

Steel to BS EN ISO 898-1: Property Class 4.8

Washers

Stainless Steel to BS 1449: Part 2: Grade 304S15

Approvals

The following water contact materials used in Wall Couplings are approved for use with potable water:-

Rilsan Nylon 11:

- ▶ WRAS, DVGW, W270, ACS & KIWA

EPDM Gaskets:

- ▶ WRAS

Every effort has been made to ensure that the information contained in this publication is accurate at the time of publishing. Crane Ltd assumes no responsibility or liability for typographical errors or omissions or for any misinterpretation of the information within the publication and reserves the right to change without notice.

Wall Couplings Order / Enquiry Form

Wall Couplings are a bespoke product and Viking Johnson requires the following information to assist with the quotation process. This page can be copied from the brochure or a form fillable PDF is available on the website www.vikingjonson.com.

Please complete the form and send via email to: info@vikingjonson.com

Company Name		Date	
Contact Name		Email	
Customer Address			
	Telephone		
	Fax		
	Quantity		
	Delivery Date		
Customer Reference No.		Fab No.	

Specifications

Nominal Diameter		Viking Johnson strongly recommends the user ensures that the wall is structurally capable of withstanding the resultant forces induced by the system working pressure and any other related influences.
Quantity		
1st End <small>(Please Tick)</small>	Man Entry <input type="checkbox"/> Coupling <input type="checkbox"/> Flanged <input type="checkbox"/> Plain End <input type="checkbox"/> Bellmouth <input type="checkbox"/> Harness <input type="checkbox"/>	
2nd End <small>(Please Tick)</small>	Man Entry <input type="checkbox"/> Coupling <input type="checkbox"/> Flanged <input type="checkbox"/> Plain End <input type="checkbox"/> Bellmouth <input type="checkbox"/> Harness <input type="checkbox"/>	
Wall Thickness		
Actual OD of Pipe		
Pipe Material <small>(Please Tick)</small>	Carbon Steel <input type="checkbox"/> Stainless Steel <input type="checkbox"/> D.I. <input type="checkbox"/> G.R.P <input type="checkbox"/> Concrete <input type="checkbox"/> PVC-U <input type="checkbox"/>	
Other please specify <input type="text"/>		
Fluid Flowing		
If Flanged, Flange Details		
If Harnessed - Stud Details <small>(Please Tick)</small>	No. <input type="checkbox"/> Diameter <input type="checkbox"/>	
Working Pressure		Puddle Flange <small>(Please Tick)</small> Yes <input type="checkbox"/> No <input type="checkbox"/>
Any Other Details		

DR11623_01_10_2024_(ISSUE-9)_GB

Distributor stamp



PIONEERS IN PIPE SOLUTIONS

46-48 WILBURY WAY
HITCHIN, HERTFORDSHIRE
SG4 0UD. UNITED KINGDOM
TELEPHONE: +44 (0)1462 443322
FAX: +44 (0)1462 443311
EMAIL: info@vikingjohnson.com

www.vikingjohnson.com

DUBAI SALES OFFICE
CRANE BS&U
BUILDING 4, OFFICE 901
THE GALLERIES
PO BOX 17415
DOWNTOWN JEBEL ALI
DUBAI. UAE
TELEPHONE: +971 4816 5800

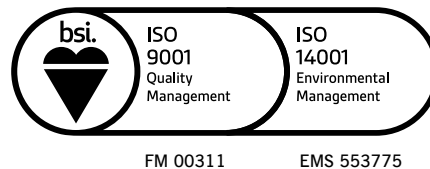

FM 00311

EMS 553775



To visit our Video Library go to:
www.youtube.com/user/CraneBSU

Every effort has been made to ensure that the information contained in this publication is accurate at the time of publishing. Crane Ltd assumes no responsibility or liability for typographical errors or omissions or for any misinterpretation of the information within the publication and reserves the right to change without notice.

All images used in this marketing literature are the exclusive property of Crane Ltd and copyrighted. These images may not be reproduced, copied, transmitted or manipulated without written permission.

- Designed and manufactured under quality management systems in accordance with BS EN ISO 9001.
- Environmental Management System accredited to ISO 14001.
- For full terms and conditions, please visit our website.