

PN16 Flange Adaptors

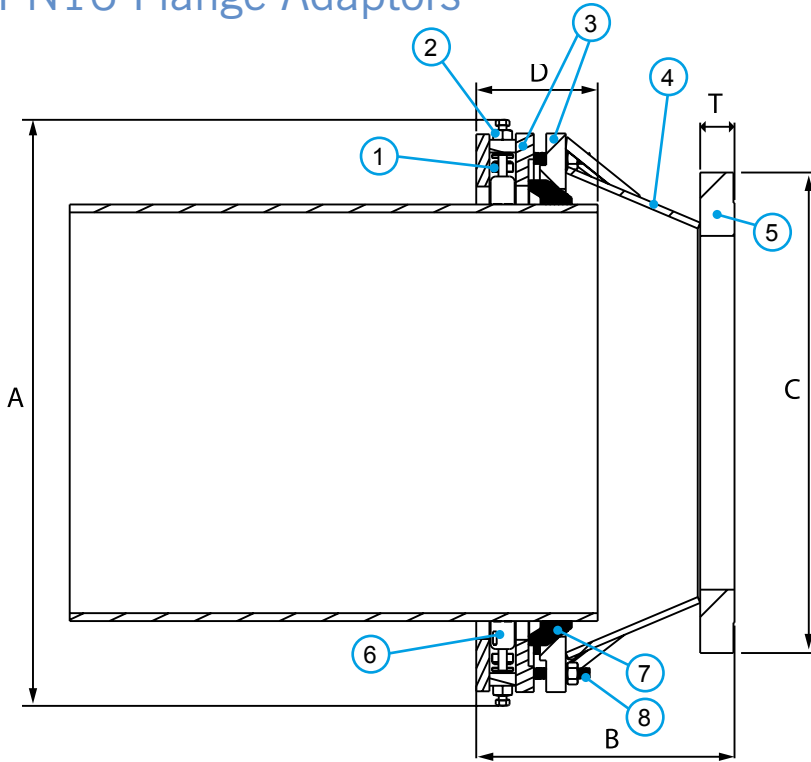

Key

- 1 = Square Bush Nut
- 2 = Bolt, Nut & Washer
- 3 = End Ring
- 4 = Centre Sleeve
- 5 = Flange Ring
- 6 = Gripper
- 7 = Gasket
- 8 = Studs



HAZARD WARNING: Lifting lugs, where provided, are designed/tested for lifting only the components to which they are attached. Failure to follow these instructions could result in property damage, serious personal injury or death. The maximum safe working load of the lifting eye is equal to the product weight.

Flange Adaptors PN16

Nom Size	Size Range		Flange Nom Size	Flange Drilling	Insertion Depth (D)		Setting Gap		Dimensions				Fasteners		Weight (kg)
	Min	Max			Min	Max	Min	Max	C	A	B	T*	Axial Stud No-size	Radial Bolt No-size	
900	892	927	800	PN16	220	245	540	565	1025	1279	785	74	22 x M20	38 x M16	636
900	892	927	900	PN16	220	245	300	325	1125	1279	545	82	22 x M20	38 x M16	624
900	926	961	900	PN16	220	245	500	525	1125	1315	745	82	22 x M20	42 x M16	694
900	958	993	900	PN16	220	245	500	525	1125	1345	745	82	22 x M20	38 x M16	718

Flange Drilling - All flanges are drilled to BS EN 1092 - part 1 and are raised face flanges *dimensions excluding 2mm raised flange.

Connections based on standard pipe OD's*

Nom Size	Range		Ductile Iron	PE	Steel / FBE Coated Steel	Cast Iron	Asbestos Cement
	Min	Max					
DN900	892	927		900mm	DN900	33" (CD) 34 (AB)	33" (CD) 34 (AB)
DN900	926	961	DN900				
DN900	958	993				36" (AB & CD)	36" (AB & CD)

*The above table is for guidance only, please ensure the OD and material of the pipe is compatible before installation

Working Pressure & Temperature Ratings

Nominal Size	Gripping Product		Flex Product		Operating Temperature
	Gas	Water	Gas	Water	
DN900	N/A	16 bar	N/A	16 bar	-20 to +60

Pipe Materials



Every effort has been made to ensure that the information contained in this publication is accurate at the time of publishing. Crane Ltd assumes no responsibility or liability for typographical errors or omissions or for any misinterpretation of the information within the publication and reserves the right to change without notice.

PN16 Flange Adaptors

Technical Information

Working pressure rating:

Water:
DN900 = 16 bar
Gas:
Not approved

Site test pressure:

1.5 times working pressure

Angularity

Flange Adaptor 4°

Gripping product suitable for

Ductile Iron / PE (PE100, SDR 13.6, 17, 21)
Steel / Cast Iron

Flex product suitable for

Ductile Iron / PE (PE100, SDR 13.6, 17, 21)
Steel / Cast Iron / Abestos Cement

Bolt Torque

	Recommended Bolt Torque (Nm) on every bolt			
	Bolt Size	Ductile Iron	PE-100	Steel and Cast Iron
Axial Fastener (For Gasket Engagement)	M20	190-210	190-210	190-210
Radial Fastener (For Grippers)	M16	190-210	140-150	110-120

For the full installation details and to ensure correct fitting, please refer to the UltraGrip DN900 installation instructions.

Temperature rating of product

Operating temperature -20°C to +60°C

Support liners – PE

A close fit Viking Johnson support liner is required when used on:
➤ All PE pipes

Use of restrained couplings on exposed pipework

UltraGrip can be used in above ground applications, so long as the pipework is supported, it is not exposed to direct sunlight and falls within the 40°C operating temperature range (between -20°C and +60°C).

Approvals

The following water contact materials used in UltraGrip are approved for use with potable water:-

Rilsan Nylon 11:

➤ WRAS, DVGW, W270, ACS & KIWA

Gasket (EPDM):

➤ WRAS, W270

Materials & Relevant Standards

1) Square Bush Nut

Cast stainless steel to ASTM A487/A487M-21, Grade CA6NM Class A

2) Bolts

Stainless steel to BS EN ISO 3506-1 Grade A4-80

2) Nuts

Stainless steel – BS1449:PT2 ISO 3506-1 Grade A4-80

2) Washers

Stainless steel – BS1449:PT2 ISO 3506-1 Grade A4-50

3) End Rings 4) Centre Sleeve

Mild steel to BS EN10025 Grade S355

5) Flange Ring

S275 Mild Steel to BS EN 10025-2

6) Gripper

Stainless steel (Cast) PH 17-4 H925 to BS EN 10088-1

7) Gasket

EPDM to BS EN 681-1

8) Studs

Stainless steel – BS EN ISO 3506-1 Grade A4-80

Coatings

End Rings / Centre Sleeve / Flange:

➤ Rilsan Nylon 11 (Black)

Bolts:

➤ Dry Film Lubricant GZ – Silver

Nuts:

➤ Dry Film Lubricant GZ – Silver

Gripper - None

Retention Insert

Nylon 6